

REVISIONS			
REV	DESCRIPTION	DATE	APPROVED
--	--	--	--

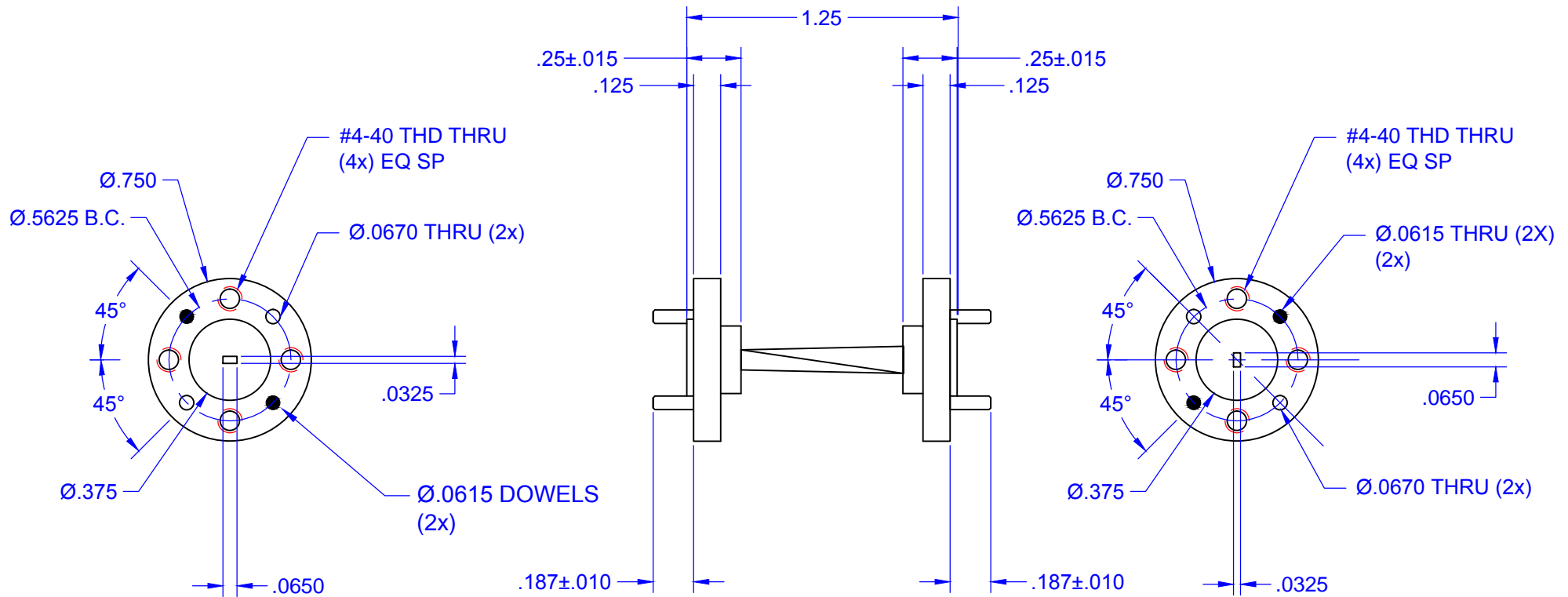
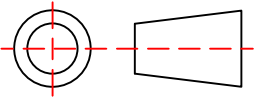

UNLESS OTHERWISE SPECIFIED ALL SURFACES $\sqrt{32}$		 THIRD ANGLE PROJECTION		Mi-Wave Millimeter Products Inc.	
DIMENSIONS ARE IN INCHES TOLERANCES ARE: DECIMALS: .1234 +/- .0005 .123 +/- .005 .12 +/- .01 ANGLES: +/- .5 DEGREES		DRAFTING: J.V.		TITLE 681D- RH-387 OUTLINE	
ALL THREADS TO BE 2A OR 2B		APPROVED: M.S.			
REF DWG #: -		DATE: 5-7-19		SIZE	DWG NO
		SHEET NO.	OF	A	24854
		1	1		